

# USER MANUAL



## Copy Declaration

The copyright of this manual belongs to Hangzhou Livoltek Power Co.,td. All rights reserved. Without the written permission of the company, any unit or individual shall not extract or reproduce part or all of the contents of this document, and shall not transmit any it in any form.

## Table of Contents

1. About This Manual	1
1.1 Scope	1
1.2 Intended Audience	1
1.3 Symbols Used	1
1.4 How to use this manual	1
2. Safety	2
2.1 Product Description	2
2.2 Important Safety Instructions	2
2.3 Symbol on the Type Label	3
3. Product Overview	5
3.1 View of the Inverter	5
3.2 Dimension	5
3.3 Terminal of the Inverter	6
3.4 System Dimension	7
4. Scope of Delivery	8
5. Mechanical Mounting	9
5.1 Requirements for Mounting	9
5.2 Mounting Instructions	12
6. Electrical Connection	14
6.1 PV Connection	15
6.2 Grid Output Connection	18
6.3 Earth Connection	20
6.4 Communication Connection	23
6.5 Wi-Fi Connection	24
6.6 AFCI (optional)	25
6.7 Installation Verification	27
7. System Operation	28
7.1 Powering ON the inverter	28
7.2 Powering OFF the Inverter	28
7.3 LEDs and Graphical Display	29
8. Communication Mode Description	30
9. Troubleshooting	33
10. Technical Data	39
11. Decommissioning	47
12. Disclaimer	49

# 1.About This Manual

## 1.1 Scope

This manual is valid for grid tied Inverter:



GT3-75K-1	GT3-75K-11	GT3-100K-1	GT3-110K-1	GT3-110K-11
GT3-125K-1	GT3-125K-11	GT3-36KL1	GT3-36KL11	GT3-40KL1
GT3-40KL11	GT3-50KL1	GT3-60KL1	GT3-60KL11	GT3-75KL1
GT3-100KM1	GT3-124KM1	GT3-125KM1	GT3-150KM1	GT3-100KM11
GT3-75K-12	GT3-100K-12	GT3-110K-12	GT3-50KL11	GT3-60KL12
GT3-124KM11				

## 1.2 Intended Audience

The manual is intended for photovoltaic (PV) inverter operating personnel and qualified electrical technicians. Any electrical Installation and maintenance of this inverter must be performed by a qualified electricians by a professional electrical with the above qualification.

## 1.3 Symbols Used

Safety instructions will be highlighted with the following symbols. These important instructions must be followed during installation, operation and maintenance of the inverter.

Symbol	Description
 <b>DANGER</b>	Indicates a hazard with a high level of risk that, if not avoided, will result in death or serious injury.
 <b>WARNING</b>	Indicates a hazard with a medium level of risk that, if not avoided, could result in death or serious injury.
 <b>CAUTION</b>	Indicates a hazard with a low level of risk that, if not avoided, could result in minor or moderate injury.
<b>NOTICE</b>	Indicates a situation that, if not avoided, could result in equipment or property damage.

## 1.4 How to use this manual

Read the manual and other related documents before performing any operation on the inverter. Documents must be stored carefully and be available at all times.

The information in this manual is subject to change without notice. Please check [www.livolttek.com](http://www.livolttek.com) for more information.

## 2 Safety

### 2.1 Product Description

LIVOLTEK this series grid tied inverter , Mainly used in industrial and commercial. The inverter generates renewable electricity from solar energy, and provides Pure Sine Wave AC output for connected equipment. Please read and follow all the instructions and cautions on the inverter and this user manual during installation, operation or maintenance at all times.

### 2.2 Important Safety Instructions

The safety instructions in this manual cannot cover all the precautions that should be followed. Perform operations considering actual onsite Conditions. LIVOLTEK shall not be held liable for any damage caused By violation of the safety instructions in this manual.

#### 2.2.1 Personnel Safety

- The inverter must be installed, electrically connected, operated and maintained by specially trained technician;
- The qualified technician must be familiar with the safety regulations of electrical system, working process of PV power generation system, and standards of local power grid;
- The technician must read through this User Manual carefully before any operations.

#### 2.2.2 Inverter Protection

##### WARNING

Do not disconnect the PV connectors when the inverter is running. Ensure that there is no voltage or current before installing or disconnecting any connectors.

All safety instructions, warning labels, and nameplate on the inverter should not be removed or covered.

##### WARNING

When the photovoltaic array is exposed to light, it supplies a DC voltage to this equipment.

##### WARNING

Do not touch any hot parts (such as the heat sink) during operation.

##### CAUTION

Hot surfaces – To reduce the risk of burns – Do not touch.

"Do not remove cover until 5 minutes after disconnecting all sources of supply."















##### NOTICE

As soon as receiving the inverter please check if it is damaged during its transportation. If yes, please contact your dealer immediately.

Only qualified personnel can change the country settings.

- Adequate ventilation must be provided for inverter installation location  
Mount the inverter in vertical direction, and ensure that no objects block the heat dissipation

## 2.3 Symbol on the Type Label

Symbol I	Explanation
	CE mark. The inverter complies with the requirements of the applicable CE guidelines.
	UKCA mark. The inverter complies with the requirements of the applicable UKCA guidelines.
	UKNI mark. The inverter complies with the requirements of the applicable UKNI guidelines.
	Direct Current (DC)
	Alternating Current (AC)
	Point of connection for grounding protection.
	RCM remark.
	SAA certification.
	Beware of hot surface. The inverter can become hot during operation. Avoid contact during operation.
	Danger of high voltages. Danger to life due to high voltages in the inverter!
	Danger Risk of electric shock!
	Observe enclosed documentation.
	The inverter can not be disposed together with the household waste. Disposal information can be found in the enclosed documentation.
	Danger to life due to high voltage. There is residual voltage in the inverter which needs 5 min to discharge. • Wait 5 min before you open the upper lid or the DC lid.

## 3 Product Overview

### 3.1 View of the inverter

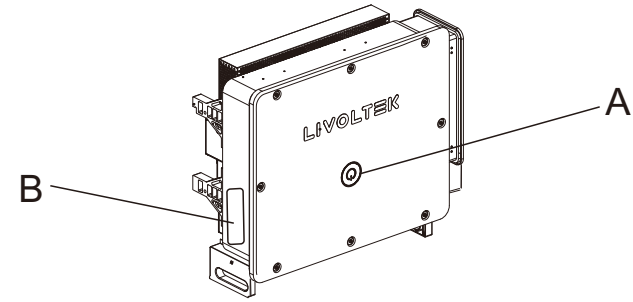

View the this Series grid-tied inverter

Position	Designation
A	LED indicator
B	Label

### 3.2 Dimension

This series of grid-tied inverter external dimensions.

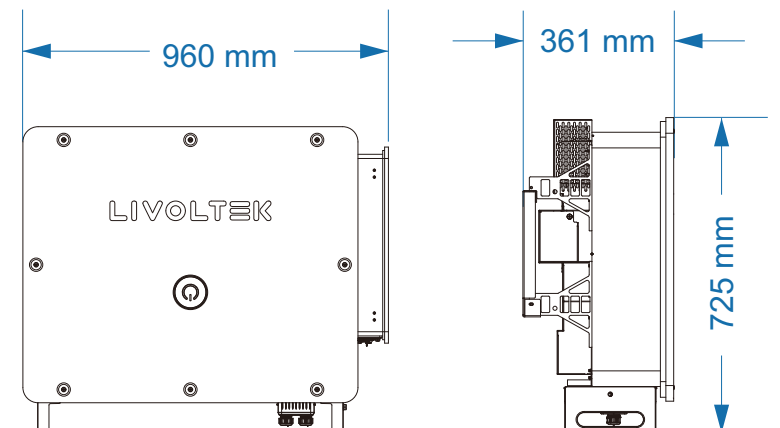

### 3.3 Terminals of the inverter

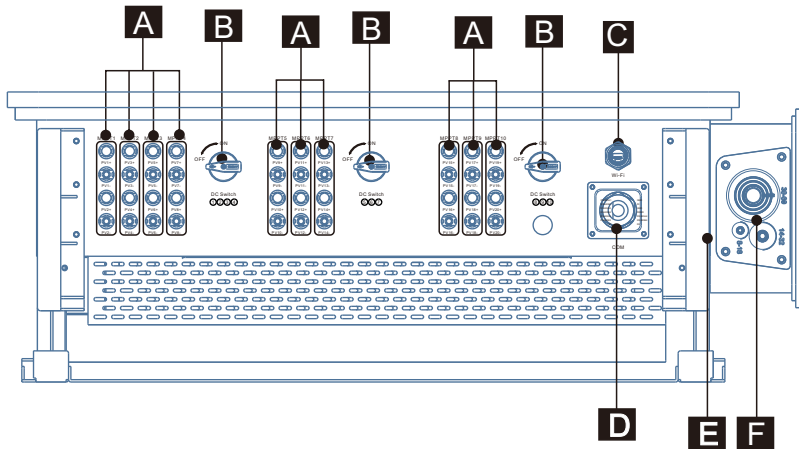

A	PV connection area
B	DC switch
C	Wi-Fi Port
D	Communication port (Meter/Parallel)
E	Earth port
F	Grid output port

### 3.4 System Diagram

This series is a transformerless three-phase grid-tied inverter. As an indispensable part of the photovoltaic power generation system, the inverter mainly converts the direct current generated by the PV modules into alternating current that is compatible with the grid, and can feed the alternating current into the public grid.

A low-voltage grid-tied PV power system

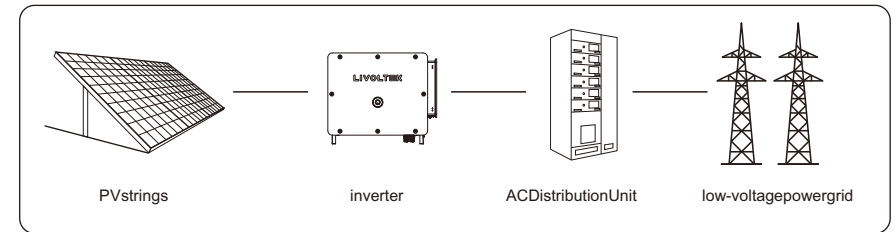

This series of inverter are suitable for TN-S, TN-C, TN-C-S, IT and TT power grid systems.

**⚠ Notice**

In IT power grid, single-phase over/under voltage and single-phase high low voltage ride through may occur due to the lack of connection of N line

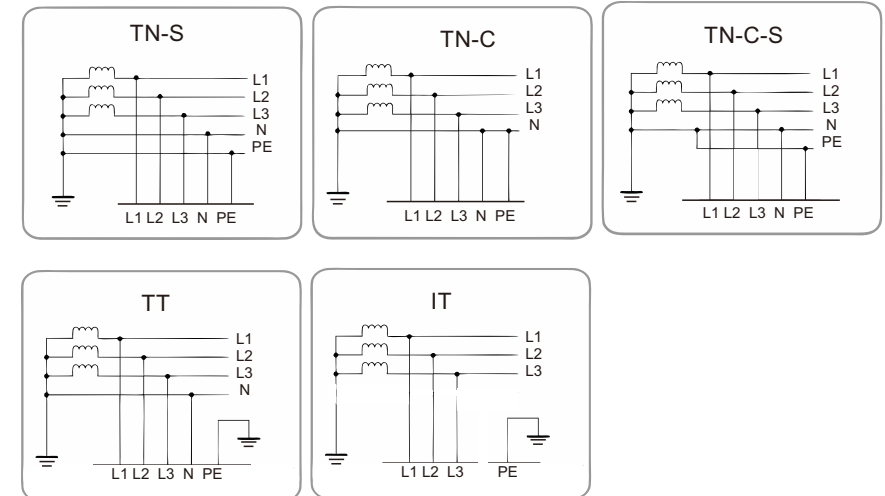

## 4 Scope of Delivery

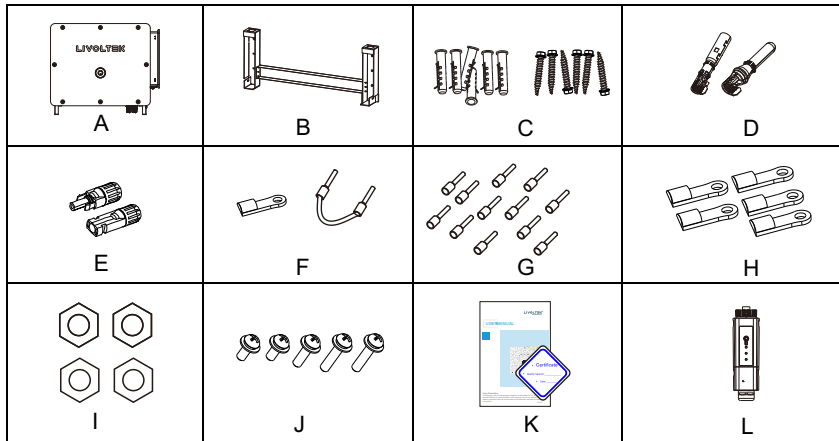

Item	QTY	Designation
A	1	Inverter
B	1	Bracket
C	4	Expansion screws for fixing mounting bracket
D	8~20	PV pin angle( positive*8~20, negative*8~20)
E	8~20	PV terminal ( positive*16/20, negative*16/20)
F	2/1	Earth Screw/Shorting Stub
G	8~20	Cold-pressed terminal
H	7	OT terminal
I	4	M12 Nuts
J	5	M5 Screw*2,M6 Screw*1,M8 Screw*2,
K	1	Certificate card /Quick installation guide
L	1	Wi-Fi

## 5 Mechanical Mounting

### 5.1 Requirements for Mounting

#### NOTICE

- In order to avoid electric shock or other injury, make sure that holes will not be drilled over any electricity or plumbing installations.
- Always follow the instructions when moving and positioning the inverter.
- Improper operation may cause injuries or serious wounds. In the case of poor ventilation, the system performance may compromise.

#### 5.1.1 Location Requirements

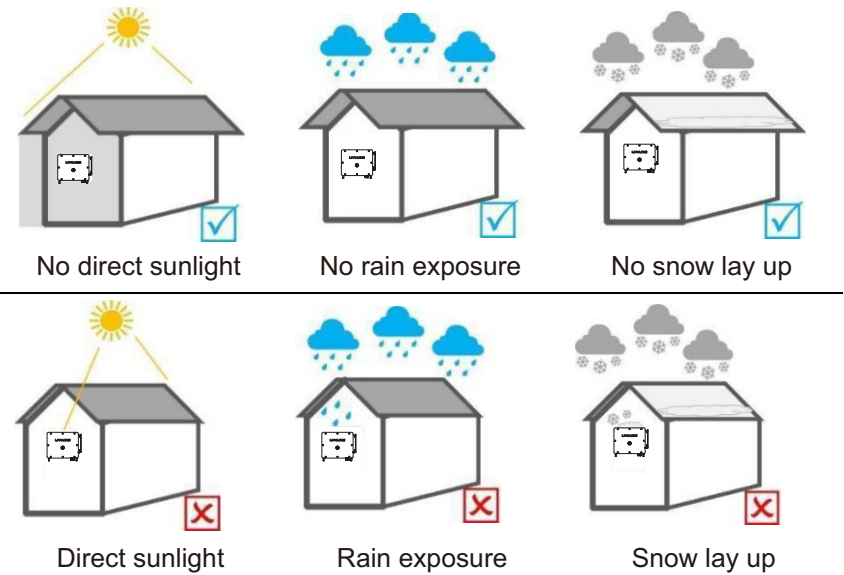

Select an optimal mounting location for safe operation, long service life ,And expected performance. During the installation and operation process, please the inverter in don't install the inverter where people may touch its casing and radiator, because these parts will be very hot during operation.

### 5.1.2 Environment Requirements

The inverter must be installed in a ventilated environment to ensure good heat dissipation. Make sure the installation site meets the following conditions:

- Not in areas where highly flammable materials are stored.
- Not in potential explosive areas.
- Not in the cool air directly.
- Not near the television antenna or antenna cable.
- Not higher than altitude of about 4000m above sea level.
- Not in environment of precipitation or humidity ( > 95%).
- Under good ventilation condition.
- The ambient temperature in the range of -30 ... +60 °C.
- The slope of the wall should be within  $\pm 5^\circ$ .
- The wall hanging the inverter should meet conditions below:
- The wall must be solid enough to bear the weight of the inverter.  
Do not install the inverter on a wall made of gypsum boards or similar materials with weak sound insulation to avoid noise disturbance in a residential area.

### 5.1.3 Angle and Space Requirements

#### NOTICE

Never install the inverter horizontally, or with a forward tilt or with a backward tilt or even with upside down. The horizontal installation can result in damage to the inverter. Install the inverter upright or at a maximum back tilt of 15 degrees to facilitate heat dissipation.

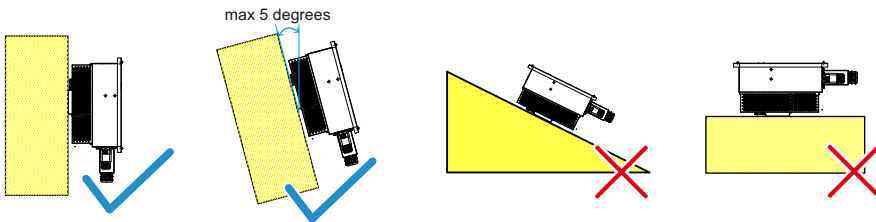

Reserve enough space when installing inverter (at least 300mm) for heat dissipation.

Reserved space dimensions of installation

Position	Min Distance
Left	600mm
Right	600mm
Up	200mm
Down	450mm
Forward	1000mm

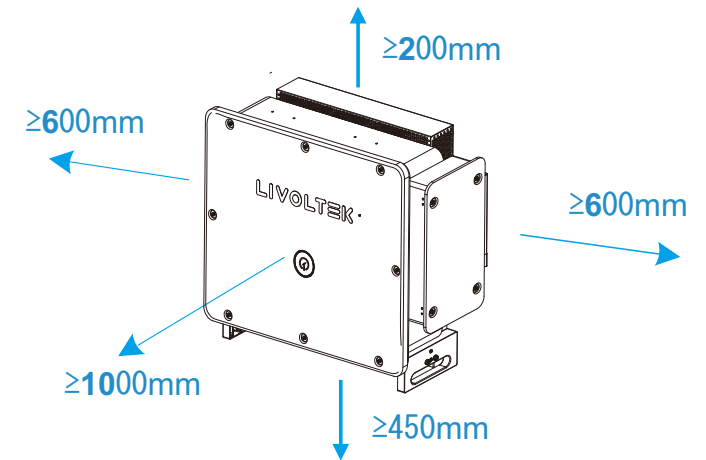

## 5.2 Mounting Instructions

Installation Tools (recommended but not limited to the following ones):  
 Protective glasses and gloves, Marker, Measuring tape, Multi-meter,  
 Wire, Crimper, Stripping pliers, Screwdriver, Manual wrench, Hammer  
 Drill and drill bit, etc.

 Bit $\Phi 10$ Hammer drill	 Rubber hammer	 Tape ruler	 Spirit level\Marker
 Protective glasses	 Hydraulic tensioner	 OT terminals press clamp	 Wire stripper
 DC Voltage (Range $\geq 1100V$ DC) Multimeter	 Euro terminal crimping tool	 Diagonal pliers	 Phillips screwdriver Straight screwdriver

### Mounting the Inverter

#### Step1: Drill holes on the wall

- Locate the appropriate drilling holes and mark it with a marker pen.
- Drill holes with driller, make sure the holes are deep enough (at least 50mm) to support the inverter.

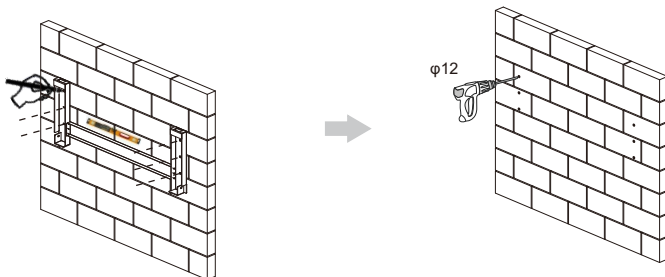

#### Step 2: Install the inverter to the wall

Insert the expansion tubes into the holes and hang the back plate, Then tighten the screws to install it.

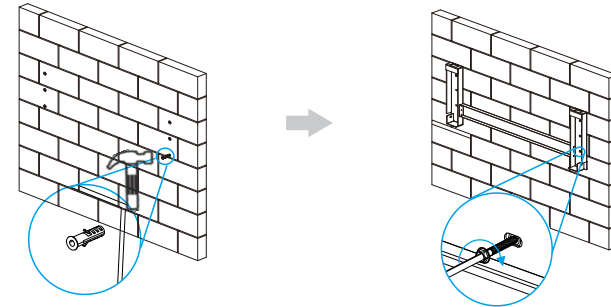

Carefully lift the inverter from the packaging box (it is recommended to arrange personnel to carry it according to the weight of the inverter), and install the four screw-in handles after lifting the inverter. Then use the bottom handle and the four installed handles to move the inverter to the installation location.

 Note: The inverter is heavy, please handle it with care.

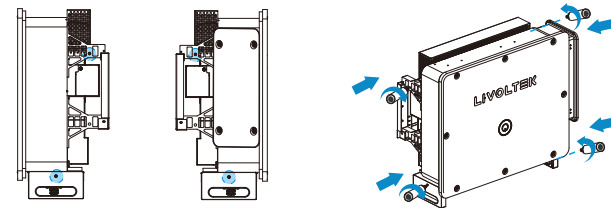

#### Step 3: Installation Self-check

Hang the inverter on the back panel and lock the side with 2\*M5 screws. (torque: 3.5N·m)

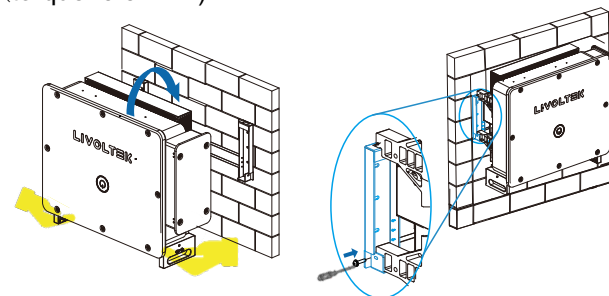

#### Step 4: Electrical Connection

Please refer to the operating instructions in the next chapter.

## 6 Electrical Connection

This chapter mainly describes the cable connections of the system. Prior to any electrical connections, keep in mind that the inverter has dual power supplies. It is mandatory for the qualified personnel to wear personal protective equipments (PPE) during the electrical work.

### DANGER

Danger to life due to a high voltage inside the inverter!

- The PV string will generate lethal high voltage when exposed to sunlight.
- Before starting electrical connections, disconnect the DC and AC circuit breakers and prevent them from inadvertent reconnection.
- Ensure that all cables are voltage free before performing cable connection.

### WARNING

- Any improper operations during cable connection can cause device damage or personal injury.
- Only qualified personnel can perform cable connection.
- All cables must be firmly attached, undamaged, properly insulated and adequately dimensioned.

### NOTICE

- Comply with the safety instructions related to the PV strings and the regulations related to the utility grid.
- All electrical connections must be in accordance with local and National standards.

## 6.1 PV Connection

Please only use the PV connectors from the accessory box for connection.

Before connecting, please make sure:

- The voltage, current and power ratings of the panels to be connected within the allowable range of the inverter. Ensure polarity is correct. Please refer to the Technical Data in chapter 9 for voltage and current limits.
- Since the inverter is transformerless, please do not ground either output of the PV panels. Ground the panel frames.
- Before connecting to PV modules, please install separately a DC circuit breaker between inverter and PV modules.
- To avoid any malfunction, do not connect any PV modules with possible current leakage to the inverter. For example, grounded PV modules will cause current leakage to the inverter. When using CIGS modules, please be sure NO grounding.
- If the inverter is equipped with a three-level lightning protection device, it's requested to use PV junction box with surge protection. Otherwise, it will cause damage on inverter when lightning occurs on PV modules.

Procedure

Model	Wire Size	Cable
GT3 75~125kW	10AWG	4-6mm <sup>2</sup>
GT3 36~75kW-L		
GT3 100~150kW-M		

### WARNING

- Use IEC61730 class-A Rating PV modules.
- When exposed to light, PV panels will generate DC voltage.
- Turn off the DC circuit breaker before connecting any wiring.
- All wiring must be performed by a qualified personnel.
- It's very important for system safety and efficient operation to use appropriate cable for PV module connection. To reduce risk of injury, please use the proper recommended cable size as below.

**⚠ WARNING**

- This unit is not provided with a GFDI device. This inverter controller must be used with an external GFDI device as required by the article 690 of the National Electrical Code for the installation location.

**Wiring Connection**

Please follow below steps to implement PV module connection:

Step1: Remove an appropriate length of the insulation layer from the positive and negative power cables using a wire stripper.

Step2. Insert the exposed areas of the positive and negative power cables into the metal terminals of the positive and negative connectors respectively and crimp them using a crimping tool.

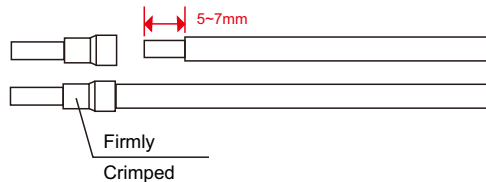

Step 3. Tighten the PV pin needle and the wiring harness to make the connection tight without looseness

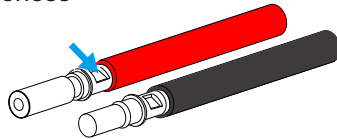

Step 4. The PV joint is divided into 2 parts - the plug and the fastening head. Insert the cable through the fastening head and the opposite plug. Note that the red and black lines correspond to different plugs. Finally, force the cable pair into the plug, will a "click" sound, which indicates that the connection is complete.

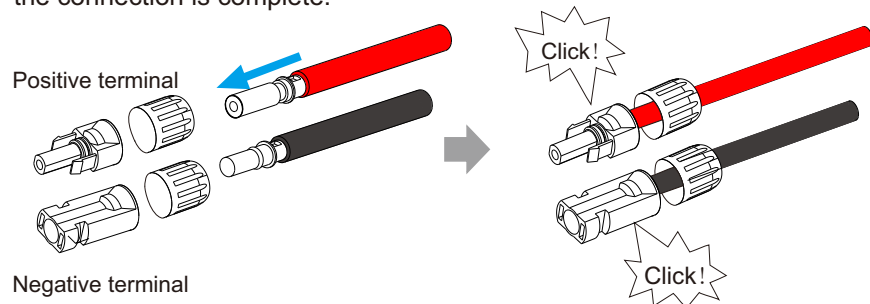

Step 5. Tighten the fastening head and into insert the corresponding positive and negative (PV-/PV+) ports of the inverter.

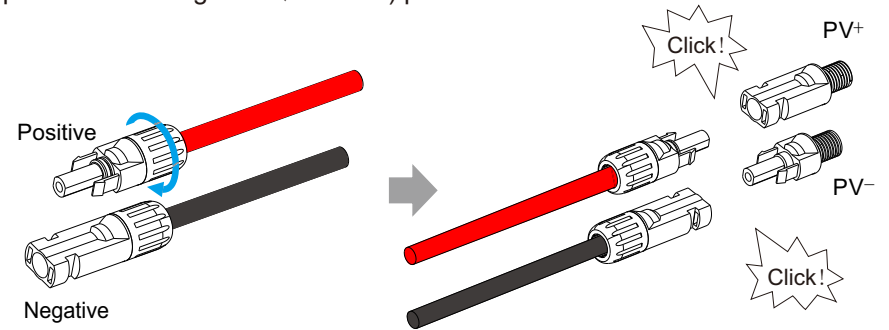

Step 6. Check correct polarity of wire connection from PV modules and PV input connectors. Then, connect positive pole (+) of connection wire to positive pole (+) of PV input connector. Connect negative pole (-) of connection wire to negative pole (-) of PV input connector.

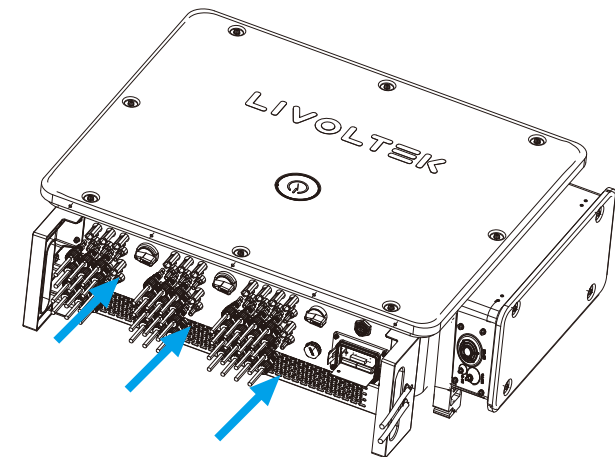

## 6.2 Grid Output Connection

### ⚠ WARNING

- The grid voltage and frequency must be in the permissible range.
- An external AC breaker must be installed between inverter and Grid input power source.  
This will ensure the inverter can be securely disconnected during maintenance and fully protected from over current of Grid input.
- All wiring must be performed by a qualified personnel.
- Before making Grid input/output connection, be sure to open DC protector or disconnection first.
- Disconnect the circuit breaker and secure it against reconnection.

Take out the Grid connector parts from the packaging. And ensure the information below before connecting the inverter to the grid:

Suggested cable requirement for Grid wires

It's very important for system safety and efficient operation to use appropriate cable for Grid input connection. To reduce risk of injury, please use the proper recommended cable size as below.

Procedure:

Model	Copper wire cross-sectional area and recommend	Cable(mm <sup>2</sup> )	Breaker	Torque Value(max)
GT3-75K(-1/-11/-12) GT3-36KL(1/11) GT3-40KL(1/11)	Five-core : 70-240mm <sup>2</sup> /60mm <sup>2</sup> Four-wires : 70-240mm <sup>2</sup> /60mm <sup>2</sup>	Single-core : 14-32 L1/L2/L3/N:30-60 Mult-core : 24-66 PE:14-32	200A	25-30N·m
GT3-100K(-1/11) GT3-50KL(1/11)			250A	
GT3-110K(-1/11/12) GT3-60KL(1/11/12)				
GT3-125K(-1/11) GT3-75KL(1/11) GT3-100KM(1/11) GT3-124KM(1/11) GT3-125KM(1/11) GT3-150KM1				

NOTE: Above are the recommended specification for conventional wiring harnesses on the AC side, and the actual wiring specifications must comply with local wiring standards.

Step1:Strip wire.

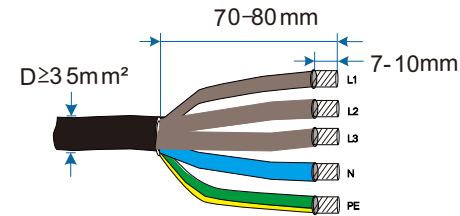

Step2 : Insert the conductors to the corresponding terminal and crimp them. Pull cables outward to check whether they are firmly installed

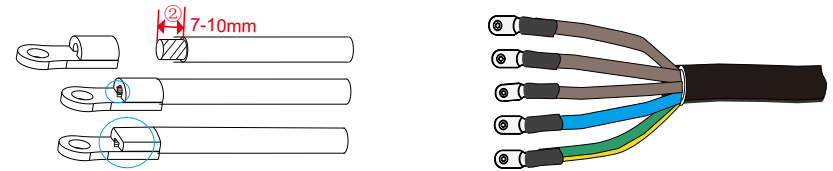

Step3 : It can be cut according to the AC wire diameter.

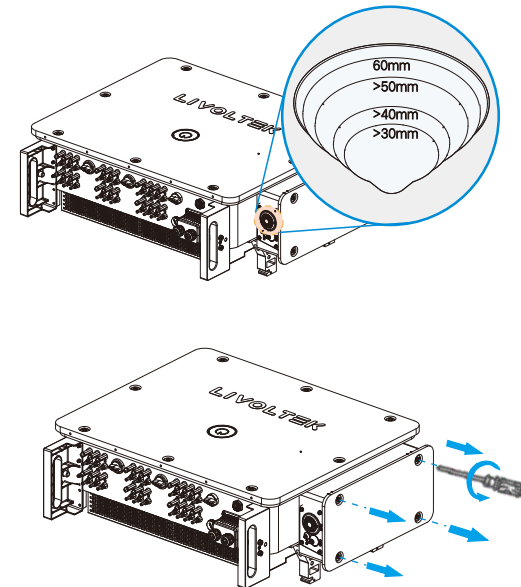

## 6.3 Communication Connection

### 6.3.1 Meter Connection (Optional)

This series grid-tied inverters should work with electric meter or current sensors to monitor load electricity consumption and limit the inverter's output power to the mains. In addition, the electricity meter can transmit the relevant electricity consumption data to the inverter or platform, which is convenient for users to read at any time.

Please note that the meter brand required by Livoltek must be used.

#### NOTICE

- Smart meter data,  $I_{ac}$  flow to the inverter is positive, flow to the grid side is negative.
- When this series of inverter are connected in parallel, you only need to install a smart meter with CT on the inverter set as the host. The installation method the same as "Meter for CT connect diagram".

Meter connection diagram:

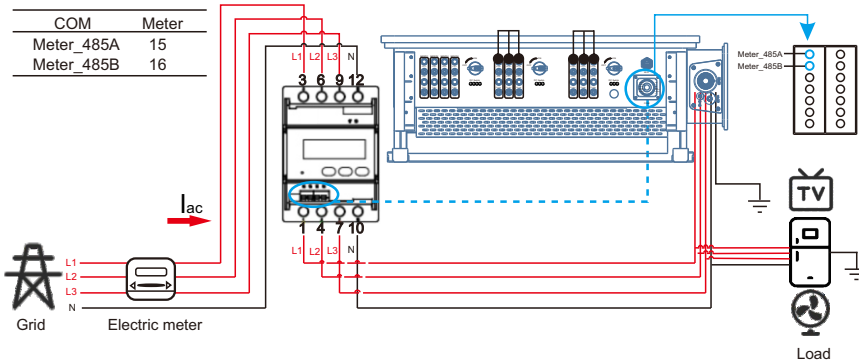

Meter for CT connection diagram:

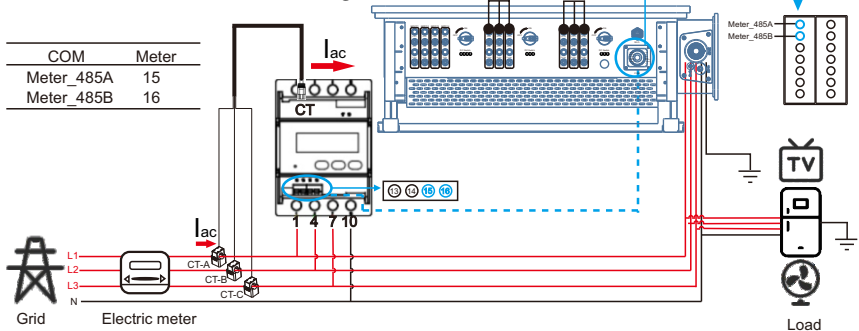

Meter for Two-type CT (>250A) connection diagram:

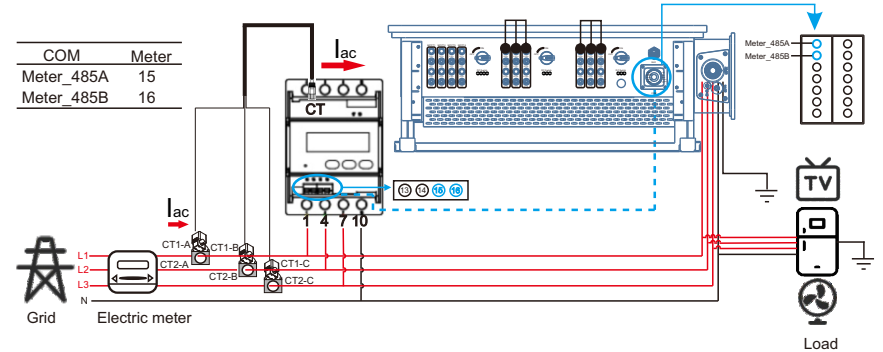

6.3.2 Parallel Connection (This function must be used with datalogger)

This series grid-tied inverters are used in large industrial and commercial applications. When multiple inverters are connected in parallel, Rs485 communication lines can be used for daisy chain connection.

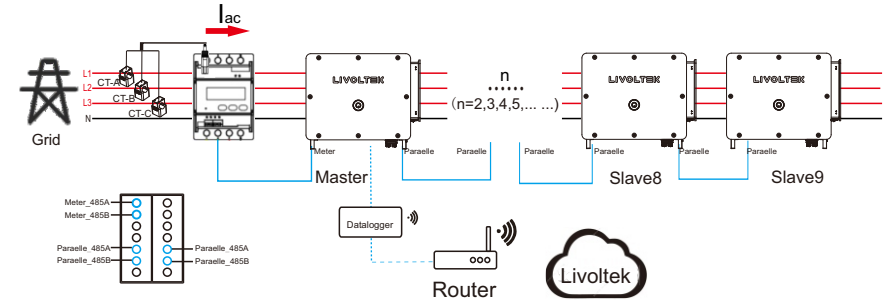

Communication connection

Step 1: Strip the wire, insert the communication terminal.  
(strip the wire: 6~8mm)

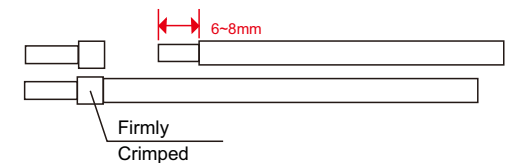

Step 2: Thread the harness into the COM waterproof cover.

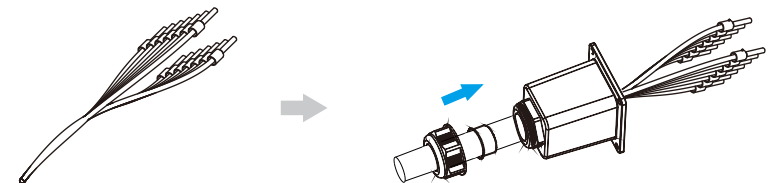

Step4: Tighten the L1/L2/L3/N/PE screws of Grid respectively, and then fasten Grid Cover. ( M6 Screw , torque : 2N·m)

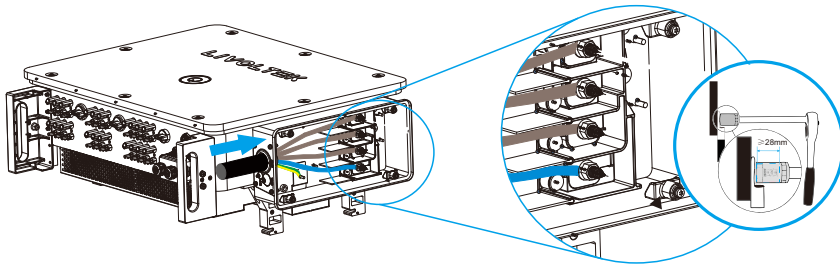

Step5: Correspondingly insert the Meter port, and lock the cover. (torque:1.2N·m)

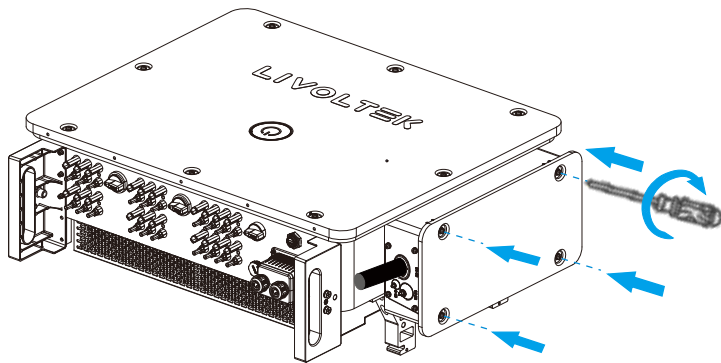

#### 6.4 Earth connection(mandatory requirement)

##### ⚠ WARNING

- Earth connection essential before connecting supply
- Inverter must be secondary earthed,the primary AC output side PE is grounded,and the secondary shell is earthed.
- Be sure that AC power source is disconnected before attempting to hardwire it to the unit.
- A cross-section of the protective earthing condutor of at least 10mm<sup>2</sup> if copper.

##### NOTICE

- Good grounding is good for resistance to surge voltage shocks and improves EMI performance. Therefore,before connecting AC, DC and communication cables, you need to ground the wires.
- For a Three inverter, simply ground the PE cable; For multi-inverter, the PE cables for all inverters need to connected to the same grounded copper strip to ensure an equipotential connection.
- If the PV end of the inverter is not connected with earth, the inverter will turn on a red light inspect and report Earth Fault. this inverter complies with IEC 62109-1 clause 13.9 for earth fault alarm monitoring

Procedure:

Model	Wire Size	Cable	Torque Valu (max)
GT3-75~125kW GT3-36~75kW-L GT3-100~150kW-M	6AWG	14-32mm <sup>2</sup>	2N · m

Step1: prepare a one-core wire, strip it 5-7mm and crimp the incoming Earth terminal;

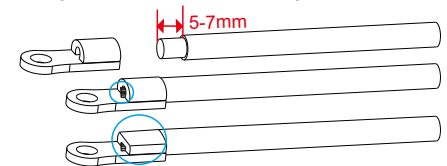

Step2: Then insert it through earth terminal and use a crimping tool to press it tightly; (M8 screw, torque:12 N · m)

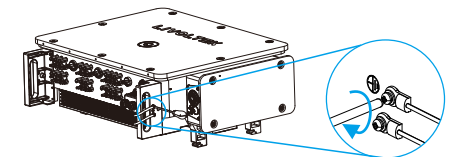

## 6.5 Wi-Fi Connection

The inverter provides a Monitoring module port, which can transmit data of the inverter to the monitoring website via Wi-Fi. ( If necessary, purchase products from Livoltek)

Monitoring module connection diagram:

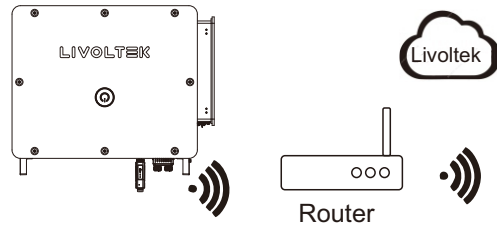

Wi-Fi module implements communication with cloud server through wireless or ethernet network to monitor inverter's data status. For more details, refer to Wi-Fi Product Application Manual.

Step 1: Disassemble Livoltek's Wi-Fi accessories, and open the waterproof plug of the Wi-Fi port on the inverter;

Step 2: Install the Wi-Fi module at the corresponding position in the inverter, and buckle tightly, you mainly need to hear a "click";

Please go to the Livoltek APP to connect to the Internet and set it up. For specific details, please refer to the Wi-Fi user manual.

## 6.6 AFCI (Optional)

Arc-Fault circuit interrupter (AFCI) refers to a photovoltaic module or cable that is not properly connected or damaged, and may produce an arc. According to UL1699B:2018, the inverter has an arc detection and interrupt identification system, which produces an arc situation, and the inverter must trip within the specified time, and can only be manually reset. According to UL1699B:2018, the inverter has an arc detection and interrupt identification system, which produces an arc situation, and the inverter must trip within the specified time, and can only be manually reset log on to the Livoltek APP, cloud platform, local Bluetooth to turn off. (go to the "Advanced Settings" interface, select "AFCI function> Setting >Disable")

### 6.6.1 AFCI fault alarm cleared

#### **Warning**

- If an arc fault error occurs, follow the steps below to troubleshoot the AFCI fault and restart the inverter.
- Do not turn off AFCI permanently.

This series has an automatic clearance mechanism for AFCI Alarms. If an alarm is triggered less than 4 times in a 24-hour period and Lasts less than 5 minutes, the inverter will automatically clear the alarm.

If more than 5 consecutive alarms are triggered within 24 hours, This Series inverter lock protection. Manual intervention is Required to manually clear the alarm and restore the normal operation Of the inverter.

When "AFCI Fault" is prompted, an arc has occurred in the PV system. The inverter will trip and shut down.

When "AFCI self-test fault" is prompted, an arc occurs in the PV system self-test. Inverter retest start.

How do I manually remove alarms?

Method 1: Livoltek App / Livoltek Cloud Platform .

Log in to the Livoltek app /Livoltek cloud platform , the main menu enters the "Settings > Advanced Settings" interface, click "Restart".



Method 2: Put the DC and AC switches of the inverter in the " OFF " position. Wait for the screen to turn off .

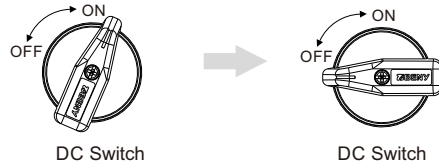

Check the wiring of the PV assembly, if there is a switch in the front stage of the PV, you need to check whether the switch wiring is abnormal. After troubleshooting, reboot the inverter and place the DC and AC switches in the " ON " position.

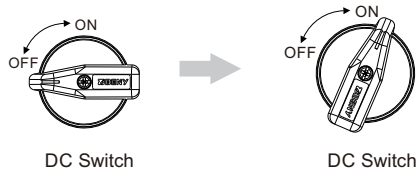

### Remark

- If the system fault display is not eliminated, please contact customer service;
- After the circuit breaker or open and close between the inverter and the power grid, the inverter will start the countdown self-test, and the self-test will jump out " AFCI self-test..." After the self-test is normal, it can be connected to the power grid.

## 6.7 Installation Verification

Check the following items after the inverter is installed.

- No other objects put on the inverter.
- All screws especially the screws used for electrical connections are tightened.
- The inverter is installed correctly and securely.
- Ground, AC, DC and Communications cables are connected tightly correctly and securely.
- Check there is no open circuit or short circuits at AC and DC terminals using multi-meter.
- Idle terminals are sealed.
- All safety warning symbols are intact and complete on the inverter.

## 7 System Operation

### 7.1 Powering ON the Inverter

Step 1: Switch ON the DC and AC circuit breaker

Wait a few seconds and the inverter will start a self-test procedure when the indicator light flashes, when it is done successfully, the green led should be solid on and the graphical display should start displaying

Step 2: Switch on the loads

The load parameters should show. It is recommended to turn on one by one, to avoid triggering the protection action due to a large instantaneous impact when the load is turned on at the same time.



### 7.2 Powering OFF the Inverter

Step 1: Turn off the loads;(If setting 0 feed-in function)

Step 2: Turn off the PV;

Step 3: Turn off the AC switch;

Step 4: Wait for at least 5 minutes after the LED and graphical display black out for the internal circuits to discharge energy;

Step 5: Disconnect all the power cables and communication cables if needed.





#### **WARNING**

After the inverter powers off the remaining electricity and heat may still cause electrical shock and body burns. Please only begin Servicing The inverter ten minutes after the power-off.

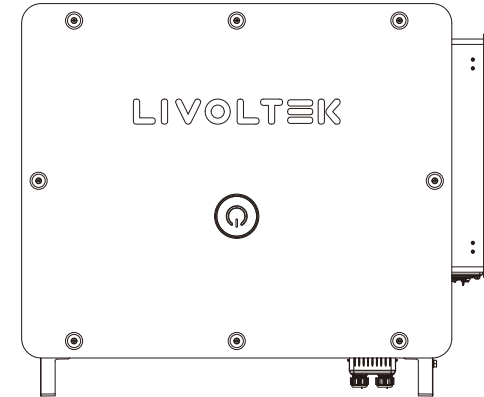
### 7.3 LEDs and Graphical Display

The inverter operation status can be obtained from observing LED indicator status.



Logo	Color	Status	Description
	Green	On	The inverter is running normally
		Off	The inverter is not operating normally
		Blink	Standby
	Green/Red	Blink	System updating
	Green	On	PID repair
	Red	On	Fault occurs
		Off	No fault occurs

## 8 Communication Mode Description

You can use the following communication modes to implement communication: Bluetooth and Wi-Fi, all of which are described as follows:

Check [www.livoltek-portal.com](http://www.livoltek-portal.com) for details operation and APP User Manual, APP User Manual is available for free from website.

### Download and Install Livoltek APP

- Method 1: Go to Google Play or Apple App Store to search Livoltek, download and install the app.
- Method 2: Scan QR code pasted on the right side of the inverter or below to download and install Livoltek app.

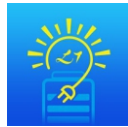

My Livoltek

### Distribution Network

Step 1: Open Livoltek APP, you can see the interface registration mode; (If You have registered, enter the account number and you can and local password to login)

Step 2: Select Wi-Fi mode;

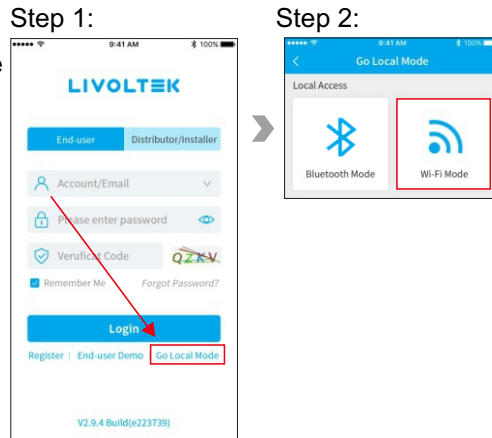

Step 3: Determine the address server, Then connect to home Wi-Fi and the Dongle Wi-Fi.

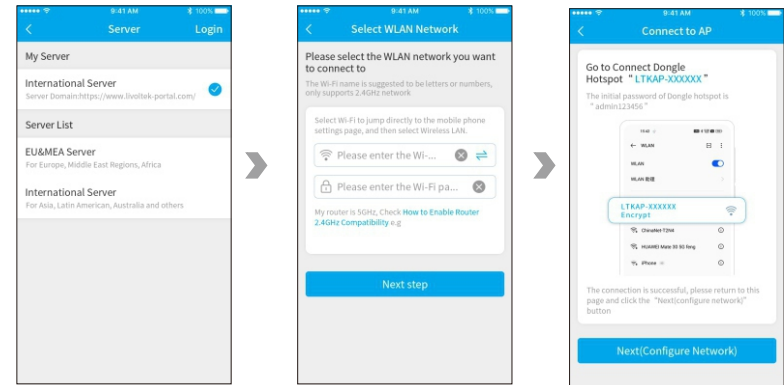

### User Register

Register an account, select the country, customer type, and fill in the account, Password and other related information.

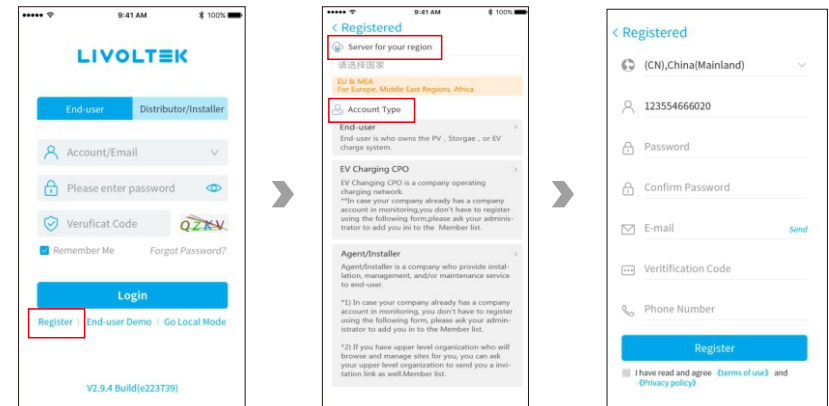

## Create Site

Select account type, enter “Site Name” 选择Choosyour region” eate a power station, and fill in the power station name, address and other related information. Then you can add to Site.

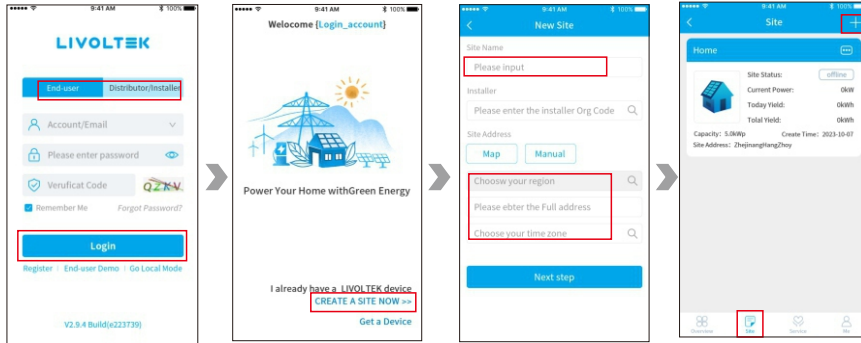

## Add Device

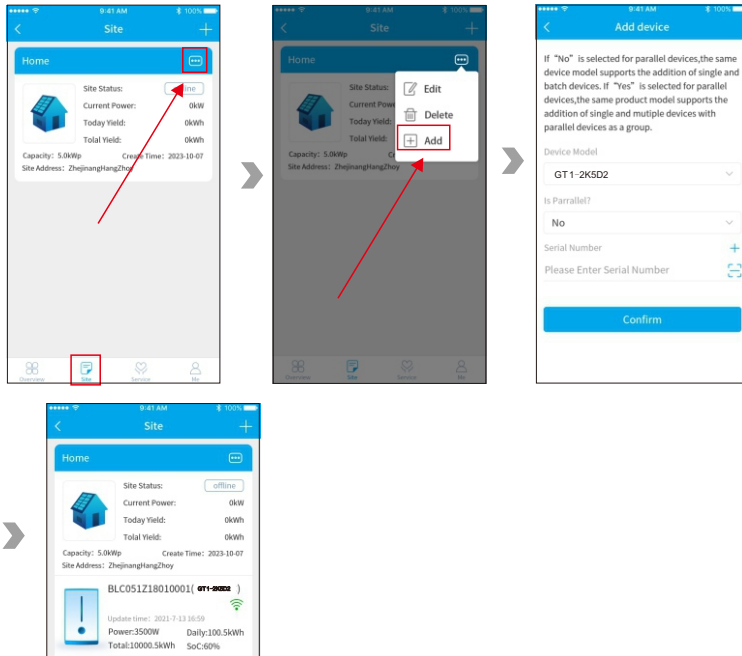

## 9 Troubleshooting

Error Message	Causes	Measures Recommended
Grid Over Volt Fault	Grid voltage is higher than permissible range or high voltage duration exceeds high voltage ride through setting.	Normally, the inverter will re-connect to the grid when the grid returns to normal. If the fault occurs repeatedly: 1. measure the actual grid voltage, if the grid voltage is really higher than the set value, please contact the local electric power company to seek a solution; 2. Check the protection parameter setting through APP or WEB, and modify the over-voltage protection value with the consent of local power operator; 3. If you confirm that the fault is not caused by the above reasons and still exists, please contact LIVOLTEK's customer service centre.
Grid Inst Volt High Fault	Grid voltage is higher than permissible range or high voltage duration exceeds high voltage ride through setting.	Normally, the inverter will re-connect to the grid when the grid returns to normal. If the fault occurs repeatedly: 1. measure the actual grid voltage, if the grid voltage is really higher than the set value, please contact the local electric power company to seek a solution; 2. Check the protection parameter setting through APP or WEB, and modify the over-voltage protection value with the consent of local power operator; 3. If you confirm that the fault is not caused by the above reasons and still exists, please contact LIVOLTEK's customer service centre.
Grid Under Volt Fault	Grid voltage is lower than permissible range.	Normally, the inverter will re-connect to the grid when the grid returns to normal. If the fault occurs repeatedly: 1. measure the actual grid voltage, if the grid voltage is really higher than the set value, please contact the local electric power company to seek a solution; 2. Check whether the protection parameter setting meets the requirements through APP or WEB; 3. Check whether the AC wiring is tight; 4. If you confirm that the fault is not caused by the above reasons and still exists, please contact LIVOLTEK's customer service centre.
AC overcurrent instantaneous	1. Abnormal internal system modules 2. System related wiring or terminals are abnormal	1.Wait for the system to return to normal 2.Disconnect the AC side switch and DC switch, if there is a battery, you need to disconnect the battery side switch, wait for 15 minutes and then close the AC and DC switches in turn, restart the system, if the fault still exists, please contact LIVOLTEK Customer Service Centre.
Grid Over Freq Fault	Grid frequency is higher than permissible range.	Normally, the inverter will re-connect to the grid when the grid returns to normal. If the fault occurs repeatedly: 1. Measure the actual grid frequency, if the grid frequency is indeed out of the set range, please contact your local power company for a solution; 2. Check whether the protection parameter setting meets the requirements through APP or WEB; 3. If you confirm that the fault is not caused by the above reasons and still exists, please contact LIVOLTEK's customer service centre.
Grid Under Freq Fault	Grid frequency is lower than permissible range.	Normally, the inverter will re-connect to the grid when the grid returns to normal. If the fault occurs repeatedly: 1. Measure the actual grid frequency, if the grid frequency is indeed out of the set range, please contact your local power company for a solution; 2. Check whether the protection parameter setting meets the requirements through APP or WEB; 3. If you confirm that the fault is not caused by the above reasons and still exists, please contact LIVOLTEK's customer service centre.
Grid power down	1. There is no power from the grid; 2. The AC line or AC switch is disconnected.	Normally, the inverter will re-connect to the grid when the grid returns to normal. If the fault occurs repeatedly: 1. Check the power grid is reliably supplied; 2. Check whether the AC wiring is tight; 3. check whether the AC cable is connected to the correct terminals (whether the fire wire is connected to the N wire inversely); 4. Check whether the AC circuit breaker is closed; 5. If you confirm that the fault is not caused by the above reasons and still exists, please contact LIVOLTEK's customer service centre.
DC component exceed standard	1. Abnormal internal system modules 2. System related wiring or terminals are abnormal	1.Wait for the system to return to normal 2.Disconnect the AC side switch and DC switch, if there is a battery, you need to disconnect the battery side switch, wait for 15 minutes and then close the AC and DC switches in turn, restart the system, if the fault still exists, please contact LIVOLTEK Customer Service Centre.

BUS average undervoltage	1. Abnormal internal system modules 2. System related wiring or terminals are abnormal	1.Wait for the system to return to normal 2.Disconnect the AC side switch and DC switch, if there is a battery, you need to disconnect the battery side switch, wait for 15 minutes and then close the AC and DC switches in turn, restart the system, if the fault still exists, please contact LIVOLTEK Customer Service Centre.
PV voltage bigger than BUS	1. Abnormal internal system modules 2. System related wiring or terminals are abnormal	1.Wait for the system to return to normal 2.Disconnect the AC side switch and DC switch, if there is a battery, you need to disconnect the battery side switch, wait for 15 minutes and then close the AC and DC switches in turn, restart the system, if the fault still exists, please contact LIVOLTEK Customer Service Centre.
PV2 hardware overcurrent fault	1. Abnormal internal system modules 2. System related wiring or terminals are abnormal	1.Wait for the system to return to normal 2.Disconnect the AC side switch and DC switch, if there is a battery, you need to disconnect the battery side switch, wait for 15 minutes and then close the AC and DC switches in turn, restart the system, if the fault still exists, please contact LIVOLTEK Customer Service Centre.
PV3 overcurrent	1. Abnormal internal system modules 2. System related wiring or terminals are abnormal	1.Wait for the system to return to normal 2.Disconnect the AC side switch and DC switch, if there is a battery, you need to disconnect the battery side switch, wait for 15 minutes and then close the AC and DC switches in turn, restart the system, if the fault still exists, please contact LIVOLTEK Customer Service Centre.
BOOST3 short circuit fault	1. Abnormal internal system modules 2. System related wiring or terminals are abnormal	1.Wait for the system to return to normal 2.Disconnect the AC side switch and DC switch, if there is a battery, you need to disconnect the battery side switch, wait for 15 minutes and then close the AC and DC switches in turn, restart the system, if the fault still exists, please contact LIVOLTEK Customer Service Centre.
Balance brige hardware fault	1. Abnormal internal system modules 2. System related wiring or terminals are abnormal	1.Wait for the system to return to normal 2.Disconnect the AC side switch and DC switch, if there is a battery, you need to disconnect the battery side switch, wait for 15 minutes and then close the AC and DC switches in turn, restart the system, if the fault still exists, please contact LIVOLTEK Customer Service Centre.
PV4 over current	1. Abnormal internal system modules 2. System related wiring or terminals are abnormal	1.Wait for the system to return to normal 2.Disconnect the AC side switch and DC switch, if there is a battery, you need to disconnect the battery side switch, wait for 15 minutes and then close the AC and DC switches in turn, restart the system, if the fault still exists, please contact LIVOLTEK Customer Service Centre.
PV5 over current	1. Abnormal internal system modules 2. System related wiring or terminals are abnormal	1.Wait for the system to return to normal 2.Disconnect the AC side switch and DC switch, if there is a battery, you need to disconnect the battery side switch, wait for 15 minutes and then close the AC and DC switches in turn, restart the system, if the fault still exists, please contact LIVOLTEK Customer Service Centre.
PV4 hardware overcurrent fault	1. Abnormal internal system modules 2. System related wiring or terminals are abnormal	1.Wait for the system to return to normal 2.Disconnect the AC side switch and DC switch, if there is a battery, you need to disconnect the battery side switch, wait for 15 minutes and then close the AC and DC switches in turn, restart the system, if the fault still exists, please contact LIVOLTEK Customer Service Centre.
PV5 hardware overcurrent fault	1. Abnormal internal system modules 2. System related wiring or terminals are abnormal	1.Wait for the system to return to normal 2.Disconnect the AC side switch and DC switch, if there is a battery, you need to disconnect the battery side switch, wait for 15 minutes and then close the AC and DC switches in turn, restart the system, if the fault still exists, please contact LIVOLTEK Customer Service Centre.
inversion switch over temperature	1. Abnormal internal system modules 2. System related wiring or terminals are abnormal	1.Wait for the system to return to normal 2.Disconnect the AC side switch and DC switch, if there is a battery, you need to disconnect the battery side switch, wait for 15 minutes and then close the AC and DC switches in turn, restart the system, if the fault still exists, please contact LIVOLTEK Customer Service Centre.
BOOST switch over temperature	1. Abnormal internal system modules 2. System related wiring or terminals are abnormal	1.Wait for the system to return to normal 2.Disconnect the AC side switch and DC switch, if there is a battery, you need to disconnect the battery side switch, wait for 15 minutes and then close the AC and DC switches in turn, restart the system, if the fault still exists, please contact LIVOLTEK Customer Service Centre.
PV2MPPT current sample abnormal	1. Abnormal internal system modules 2. System related wiring or terminals are abnormal	1.Wait for the system to return to normal 2.Disconnect the AC side switch and DC switch, if there is a battery, you need to disconnect the battery side switch, wait for 15 minutes and then close the AC and DC switches in turn, restart the system, if the fault still exists, please contact LIVOLTEK Customer Service Centre.
Control board power undervoltage	1. Abnormal internal system modules 2. System related wiring or terminals are abnormal	1.Wait for the system to return to normal 2.Disconnect the AC side switch and DC switch, if there is a battery, you need to disconnect the battery side switch, wait for 15 minutes and then close the AC and DC switches in turn, restart the system, if the fault still exists, please contact LIVOLTEK Customer Service Centre.

Hardware verion get fault	1. Abnormal internal system modules 2. System related wiring or terminals are abnormal	1.Wait for the system to return to normal 2.Disconnect the AC side switch and DC switch, if there is a battery, you need to disconnect the battery side switch, wait for 15 minutes and then close the AC and DC switches in turn, restart the system, if the fault still exists, please contact LIVOLTEK Customer Service Centre.
Mode high temperature	1. Abnormal internal system modules 2. System related wiring or terminals are abnormal	1.Wait for the system to return to normal 2.Disconnect the AC side switch and DC switch, if there is a battery, you need to disconnect the battery side switch, wait for 15 minutes and then close the AC and DC switches in turn, restart the system, if the fault still exists, please contact LIVOLTEK Customer Service Centre.
Ambient temperature is too high	The temperature inside the chassis is too high; Excessive temperature of the operating environment.	Normally, the inverter will re-connect to the grid when the grid returns to normal. If the fault occurs repeatedly: 1. Check if the ambient temperature of the machine is too high 2. Check whether the machine is in an easily ventilated place 3. Check whether the machine is in direct light, if so, please appropriate shade 4. Check whether the fan is running normally, if not, please replace the fan 5. If you confirm that the fault is not caused by the above reasons and still exists, please contact LIVOLTEK's customer service centre.
System low insulation impedance	Insulation impedance of the battery board to ground is less than the standard value.	Normally, the inverter will re-connect to the grid when the grid returns to normal. If the fault occurs repeatedly: 1. Check whether the ISO impedance protection value is too high through APP or WEB, and confirm that it meets the requirements of local regulations; 2. Check the PV and DC cable impedance to ground, if there is a short circuit or cable insulation is broken, please take corrective measures; 3. If the cable is normal and the fault occurs on a rainy day, reconfirm after the weather improves; 4. If you confirm that the fault is not caused by the above reasons and still exists, please contact LIVOLTEK's customer service centre.
Leakage current sample fault	1. Abnormal internal system modules 2. System related wiring or terminals are abnormal	1.Wait for the system to return to normal 2.Disconnect the AC side switch and DC switch, if there is a battery, you need to disconnect the battery side switch, wait for 15 minutes and then close the AC and DC switches in turn, restart the system, if the fault still exists, please contact LIVOLTEK Customer Service Centre.
Current unbalance fault	1. Abnormal internal system modules 2. System related wiring or terminals are abnormal	1.Wait for the system to return to normal 2.Disconnect the AC side switch and DC switch, if there is a battery, you need to disconnect the battery side switch, wait for 15 minutes and then close the AC and DC switches in turn, restart the system, if the fault still exists, please contact LIVOLTEK Customer Service Centre.
Input config abnormal	1. Abnormal internal system modules 2. System related wiring or terminals are abnormal	1.Wait for the system to return to normal 2.Disconnect the AC side switch and DC switch, if there is a battery, you need to disconnect the battery side switch, wait for 15 minutes and then close the AC and DC switches in turn, restart the system, if the fault still exists, please contact LIVOLTEK Customer Service Centre.
R-phase current sample fault	1. Abnormal internal system modules 2. System related wiring or terminals are abnormal	1.Wait for the system to return to normal 2.Disconnect the AC side switch and DC switch, if there is a battery, you need to disconnect the battery side switch, wait for 15 minutes and then close the AC and DC switches in turn, restart the system, if the fault still exists, please contact LIVOLTEK Customer Service Centre.
S-phase current sample fault	1. Abnormal internal system modules 2. System related wiring or terminals are abnormal	1.Wait for the system to return to normal 2.Disconnect the AC side switch and DC switch, if there is a battery, you need to disconnect the battery side switch, wait for 15 minutes and then close the AC and DC switches in turn, restart the system, if the fault still exists, please contact LIVOLTEK Customer Service Centre.
Fan alarm	1. Abnormal internal system modules 2. System related wiring or terminals are abnormal	1. The inverter can continue to running; 2. Check whether cables and terminals related to the alarm are abnormal, and rectify the anomalies such as foreign bodies in the environment. 3. If the alarm persists, contact the Livoltek customer service center.
AC lightning protect alarm	1. Abnormal internal system modules 2. System related wiring or terminals are abnormal	1. The inverter can continue to running; 2. Check whether cables and terminals related to the alarm are abnormal, and rectify the anomalies such as foreign bodies in the environment. 3. If the alarm persists, contact the Livoltek customer service center.

Current leakage excess	The leakage current exceeds the permissible range.	1. Humid environment of the PV panel or bad light will lead to this fault, normally, the inverter will be re-connected to the grid after the environment is improved; 2. If the environment is normal, check whether the insulation of DC and AC cables is normal; 3. If you confirm that the fault is not caused by the above reasons and still exists, please contact LIVOLTEK's customer service centre.
Grid abnormal	Self-test before Grid-connection	Normally, the inverter will re-connect to the grid when the grid returns to normal. If the fault occurs repeatedly: 1. measure the actual grid voltage, if the grid voltage is really higher than the set value, please contact the local electric power company to seek a solution; 2.If you confirm that the fault is not caused by the above reasons and still exists, please contact LIVOLTEK's customer service centre.
10 min grid over voltage	Grid voltage is higher than the set voltage protection value or the duration of high voltage exceeds the set value of high voltage ride-through	Normally, the inverter will re-connect to the grid when the grid returns to normal. If the fault occurs repeatedly: 1. measure the actual grid voltage, if the grid voltage is really higher than the set value, please contact the local electric power company to seek a solution; 2. Check the protection parameter setting through APP or WEB, and modify the over-voltage protection value with the consent of local power operator; 3. If you confirm that the fault is not caused by the above reasons and still exists, please contact LIVOLTEK's customer service centre.
Inversion side software overcurrent	1. Abnormal internal system modules 2. System related wiring or terminals are abnormal	1.Wait for the system to return to normal 2.Disconnect the AC side switch and DC switch, if there is a battery, you need to disconnect the battery side switch, wait for 15 minutes and then close the AC and DC switches in turn, restart the system, if the fault still exists, please contact LIVOLTEK Customer Service Centre.
Grid Volt Unbalan Fault	Inverter detects voltage imbalance between phases of the grid	Normally, the inverter will re-connect to the grid when the grid returns to normal. If the fault occurs repeatedly: 1. measure the actual grid voltage, if the grid voltage is really higher than the set value, please contact the local electric power company to seek a solution; 2. If the phase voltage difference of each phase is within the permissible range of the local power company, modify the grid voltage imbalance parameter via APP or WEB; 3. If you confirm that the fault is not caused by the above reasons and still exists, please contact LIVOLTEK's customer service centre.
Grid protect self check fail	1. Abnormal internal system modules 2. System related wiring or terminals are abnormal	1.Wait for the system to return to normal 2.Disconnect the AC side switch and DC switch, if there is a battery, you need to disconnect the battery side switch, wait for 15 minutes and then close the AC and DC switches in turn, restart the system, if the fault still exists, please contact LIVOLTEK Customer Service Centre.
Bypass overload fault	1. Abnormal internal system modules 2. System related wiring or terminals are abnormal	1.Wait for the system to return to normal 2.Disconnect the AC side switch and DC switch, if there is a battery, you need to disconnect the battery side switch, wait for 15 minutes and then close the AC and DC switches in turn, restart the system, if the fault still exists, please contact LIVOLTEK Customer Service Centre.
Bus voltage instant over	1. Abnormal internal system modules 2. System related wiring or terminals are abnormal	1.Wait for the system to return to normal 2.Disconnect the AC side switch and DC switch, if there is a battery, you need to disconnect the battery side switch, wait for 15 minutes and then close the AC and DC switches in turn, restart the system, if the fault still exists, please contact LIVOLTEK Customer Service Centre.
PV access fault	1. Abnormal internal system modules 2. System related wiring or terminals are abnormal	1.Wait for the system to return to normal 2.Disconnect the AC side switch and DC switch, if there is a battery, you need to disconnect the battery side switch, wait for 15 minutes and then close the AC and DC switches in turn, restart the system, if the fault still exists, please contact LIVOLTEK Customer Service Centre.
BUS Volt Unbalance	1. Abnormal internal system modules 2. System related wiring or terminals are abnormal	1.Wait for the system to return to normal 2.Disconnect the AC side switch and DC switch, if there is a battery, you need to disconnect the battery side switch, wait for 15 minutes and then close the AC and DC switches in turn, restart the system, if the fault still exists, please contact LIVOLTEK Customer Service Centre.
DC contactor fault	1. Abnormal internal system modules 2. System related wiring or terminals are abnormal	1.Wait for the system to return to normal 2.Disconnect the AC side switch and DC switch, if there is a battery, you need to disconnect the battery side switch, wait for 15 minutes and then close the AC and DC switches in turn, restart the system, if the fault still exists, please contact LIVOLTEK Customer Service Centre.

DC lightning protect alarm	1. Abnormal internal system modules 2. System related wiring or terminals are abnormal	1. The inverter can continue to running; 2. Check whether cables and terminals related to the alarm are abnormal, and rectify the anomalies such as foreign bodies in the environment. 3. If the alarm persists, contact the Livoltek customer service center.
PV1 abnormal alarm	1. Abnormal internal system modules 2. System related wiring or terminals are abnormal	1. The inverter can continue to running; 2. Check whether cables and terminals related to the alarm are abnormal, and rectify the anomalies such as foreign bodies in the environment. 3. If the alarm persists, contact the Livoltek customer service center.
PV2 abnormal alarm	1. Abnormal internal system modules 2. System related wiring or terminals are abnormal	1. The inverter can continue to running; 2. Check whether cables and terminals related to the alarm are abnormal, and rectify the anomalies such as foreign bodies in the environment. 3. If the alarm persists, contact the Livoltek customer service center.
PV3 abnormal alarm	1. Abnormal internal system modules 2. System related wiring or terminals are abnormal	1. The inverter can continue to running; 2. Check whether cables and terminals related to the alarm are abnormal, and rectify the anomalies such as foreign bodies in the environment. 3. If the alarm persists, contact the Livoltek customer service center.
PV4 abnormal alarm	1. Abnormal internal system modules 2. System related wiring or terminals are abnormal	1. The inverter can continue to running; 2. Check whether cables and terminals related to the alarm are abnormal, and rectify the anomalies such as foreign bodies in the environment. 3. If the alarm persists, contact the Livoltek customer service center.
Fan2 stall alarm	1. Abnormal internal system modules 2. System related wiring or terminals are abnormal	1. The inverter can continue to running; 2. Check whether cables and terminals related to the alarm are abnormal, and rectify the anomalies such as foreign bodies in the environment. 3. If the alarm persists, contact the Livoltek customer service center.
BUS average voltage is low	1. Abnormal internal system modules 2. System related wiring or terminals are abnormal	1. The inverter can continue to running; 2. Check whether cables and terminals related to the alarm are abnormal, and rectify the anomalies such as foreign bodies in the environment. 3. If the alarm persists, contact the Livoltek customer service center.
Hardware fault	1. Abnormal internal system modules 2. System related wiring or terminals are abnormal	1. The inverter can continue to running; 2. Check whether cables and terminals related to the alarm are abnormal, and rectify the anomalies such as foreign bodies in the environment. 3. If the alarm persists, contact the Livoltek customer service center.
BUS voltage is instantaneously high	1. Abnormal internal system modules 2. System related wiring or terminals are abnormal	1. The inverter can continue to running; 2. Check whether cables and terminals related to the alarm are abnormal, and rectify the anomalies such as foreign bodies in the environment. 3. If the alarm persists, contact the Livoltek customer service center.
BUS average voltage is high	1. Abnormal internal system modules 2. System related wiring or terminals are abnormal	1. The inverter can continue to running; 2. Check whether cables and terminals related to the alarm are abnormal, and rectify the anomalies such as foreign bodies in the environment. 3. If the alarm persists, contact the Livoltek customer service center.
BUS voltage is transient unbalanced	1. Abnormal internal system modules 2. System related wiring or terminals are abnormal	1. The inverter can continue to running; 2. Check whether cables and terminals related to the alarm are abnormal, and rectify the anomalies such as foreign bodies in the environment. 3. If the alarm persists, contact the Livoltek customer service center.
BUS average voltage is unbalanced	1. Abnormal internal system modules 2. System related wiring or terminals are abnormal	1. The inverter can continue to running; 2. Check whether cables and terminals related to the alarm are abnormal, and rectify the anomalies such as foreign bodies in the environment. 3. If the alarm persists, contact the Livoltek customer service center.
The output current imbalance alarm is generated	1. Abnormal internal system modules 2. System related wiring or terminals are abnormal	1. The inverter can continue to running; 2. Check whether cables and terminals related to the alarm are abnormal, and rectify the anomalies such as foreign bodies in the environment. 3. If the alarm persists, contact the Livoltek customer service center.

PID impedance anomaly alarm	1. Abnormal internal system modules 2. System related wiring or terminals are abnormal	1. The inverter can continue to running; 2. Check whether cables and terminals related to the alarm are abnormal, and rectify the anomalies such as foreign bodies in the environment. 3. If the alarm persists, contact the Livoltek customer service center.
PID function anomaly alarm	1. Abnormal internal system modules 2. System related wiring or terminals are abnormal	1. The inverter can continue to running; 2. Check whether cables and terminals related to the alarm are abnormal, and rectify the anomalies such as foreign bodies in the environment. 3. If the alarm persists, contact the Livoltek customer service center.
AFCI Fault	AFCI fault on DC side of inverter	1. Disconnect the DC power, check whether there are broken cables, loose connection terminals or fuses and poor contact on the DC side, or burn marks on the parts; if there are, replace the broken cables, tighten the loose connection terminals or fuses, and replace the parts with burn marks; 2. After completing step 1 DC side inspection and rectification and repair, reconnect the DC power and clear the AFCI fault through APP or WEB, the inverter will operate normally again; 3. If you confirm that the fault is not caused by the above reasons and still exists, please contact LIVOLTEK's customer service centre.
External fan 1 stall	1. Abnormal internal system modules 2. System related wiring or terminals are abnormal	1. Abnormal internal system modules 2. System related wiring or terminals are abnormal 3. There's a foreign object, causing a blockage
External fan 2 stall	1. Abnormal internal system modules 2. System related wiring or terminals are abnormal	1. Abnormal internal system modules 2. System related wiring or terminals are abnormal 3. There's a foreign object, causing a blockage

## 10 Technical Data

Technical Data	GT3-75-12	GT3-75K-11	GT3-75K-1	GT3-100K-12
<b>PV Input Data</b>				
Max. DC Input Power [Wp]	150%			
Max. DC Input Voltage[V]	1100			
Min PV input voltage[V]	180			
Start-up DC Input Voltage[V]	200			
Nominal DC Input Voltage[V]	600			
MPPT Operating Range[V]	180-1000			
Max. DC Input Current[A]	4*40	6*40	8*40	6*40
Max. Short Circuit current[A]	4*52	6*52	8*52	6*52
No. of MPPTs	4	6	8	6
No. of Strings per MPP Trackers	4*2	6*2	8*2	6*2
<b>AC Output Data</b>				
Nominal Output Power [W]	75000	75000	75000	100000
Max. Apparent Power [VA]	75000	75000	75000	110000
Rated AC Grid Output Current[A]	114.0	114.0	114.0	151.9
Max. AC Output Current[A]	114.0	114.0	114.0	167.1
Rated AC Grid Voltage[V]	3L/N/PE, 3L/PE, 220/380, 230/400, 240/415			
Rated Grid Frequency [Hz]	50/60			
Power Factor	> 0.99 Rated power (Adjustable 0.8 Leading - 0.8Lagging)			
Output THDi (@Nominal Output)	<3%			
<b>Efficiency</b>				
Max. Efficiency[%]	98.50%	98.50%	98.50%	98.50%
Euro Efficiency[%]	98.30%	98.30%	98.30%	98.30%
MPPT Efficiency[%]	>99%			
<b>General Data</b>				
Dimensions[W*H*D] [mm]	960*725*361			
Weight [kg]	≤87			
Mounting Information	Wall Mounting			
Protection Degree	IP66			
Cooling	Smart forced air cooling			
Operating temperature range (T <sub>ref</sub> )	-30 °C ... +60 °C (derating at 45°C)			
Relative Humidity	0-100%			
Max. Operating Altitude[m]	4000(≥3000)			
Typical Noise Emission(dB)	< 75			
Night Self Consumption [W]	< 4			
Display	LED+APP			
Communication	RS485 (Meter/GEN/DRM 0) ,Wi-Fi			
Topology	Transformerless			
<b>Certifications and Standards</b>				
Grid Regulation	IEC61727, IEC62116, EN50549			
Safety	IEC62109-1/-2			
EMC	EN61000-6-1/2/3/4			
Standard Warranty[years]	5 /10 (optional)			

Technical Data	GT3-100K-11	GT3-100K-1	GT3-110K-12	GT3-110K-11
<b>PV Input Data</b>				
Max. DC Input Power [Wp]	150%			
Max. DC Input Voltage[V]	1100			
Min PV input voltage[V]	180			
Start-up DC Input Voltage[V]	200			
Nominal DC Input Voltage[V]	600			
MPPT Operating Range[V]	180-1000			
Max. DC Input Current[A]	8*40	10*40	6*40	8*40
Max. Short Circuit current[A]	8*52	10*52	6*52	8*52
No. of MPPTs	8	10	6	8
No. of Strings per MPP Tackers	8*2	10*2	6*2	8*2
<b>AC Output Data</b>				
Nominal Output Power [W]	100000	100000	110000	110000
Max. Apparent Power [VA]	110000	110000	121000	121000
Rated AC Grid Output Current[A]	151.9	151.9	167.1	167.1
Max. AC Output Current[A]	167.1	167.1	183.8	183.8
Rated AC Grid Voltage[V]	3L/N/PE, 3L/PE, 220/380, 230/400, 240/415			
Rated Grid Frequency [Hz]	50/60			
Power Factor	> 0.99 Rated power (Adjustable 0.8 Leading - 0.8Lagging)			
Output THDi (@Nominal Output)	<3%			
<b>Efficiency</b>				
Max. Efficiency[%]	98.50%	98.50%	98.50%	98.50%
Euro Efficiency[%]	98.30%	98.30%	98.30%	98.30%
MPPT Efficiency[%]	>99%			
<b>General Data</b>				
Dimensions[W*H*D] [mm]	960*725*361			
Weight [kg]	≤87			
Mounting Information	Wall Mounting			
Protection Degree	IP66			
Cooling	Smart forced air cooling			
Operating Temperature Range [°C]	-30 °C ... +60 °C (derating at 45°C)			
Relative Humidity	0-100%			
Max. Operating Altitude[m]	4000(≥3000)			
Typical Noise Emission(dB)	< 75			
Night Self Consumption [W]	< 4			
Display	LED+APP			
Communication	RS485 (Meter/GEN/DRM 0) ,Wi-Fi			
Topology	Transformerless			
<b>Certifications and Standards</b>				
Grid Regulation	IEC61727, IEC62116, EN50549			
Safety	IEC62109-1/-2			
EMC	EN61000-6-1/2/3/4			
Standard Warranty[years]	5 /10 (optional)			

Technical Data	GT3-110K-1	GT3-125K-11	GT3-125K-1
<b>PV Input Data</b>			
Max. DC Input Power [Wp]	150%		
Max. DC Input Voltage[V]	1100		
Min PV input voltage[V]	180		
Start-up DC Input Voltage[V]	200		
Nominal DC Input Voltage[V]	600		
MPPT Operating Range[V]	180-1000		
Max. DC Input Current[A]	10*40	8*40	10*40
Max. Short Circuit current[A]	10*52	8*52	10*52
No. of MPPTs	10	8	10
No. of Strings per MPP Tackers	10*2	8*2	10*2
<b>AC Output Data</b>			
Nominal Output Power [W]	110000	125000	125000
Max. Apparent Power [VA]	121000	137500	137500
Rated AC Grid Output Current[A]	167.1	189.9	189.9
Max. AC Output Current[A]	183.8	208.9	208.9
Rated AC Grid Voltage[V]	3L/N/PE, 3L/PE, 220/380, 230/400, 240/415		
Rated Grid Frequency [Hz]	50/60		
Power Factor	> 0.99 Rated power (Adjustable 0.8 Leading - 0.8Lagging)		
Output THDi (@Nominal Output)	<3%		
<b>Efficiency</b>			
Max. Efficiency[%]	98.50%	98.50%	98.50%
Euro Efficiency[%]	98.30%	98.30%	98.30%
MPPT Efficiency[%]	>99%		
<b>General Data</b>			
Dimensions[W*H*D] [mm]	960*725*361		
Weight [kg]	≤87		
Mounting Information	Wall Mounting		
Protection Degree	IP66		
Cooling	Smart forced air cooling		
Operating Temperature Range [°C]	-30 °C ... +60 °C (derating at 45°C)		
Relative Humidity	0-100%		
Max. Operating Altitude[m]	4000(≥3000)		
Typical Noise Emission(dB)	< 75		
Night Self Consumption [W]	< 4		
Display	LED+APP		
Communication	RS485 (Meter/GEN/DRM 0) ,Wi-Fi		
Topology	Transformerless		
<b>Certifications and Standards</b>			
Grid Regulation	IEC61727, IEC62116, EN50549		
Safety	IEC62109-1/-2		
EMC	EN61000-6-1/2/3/4		
Standard Warranty[years]	5 /10 (optional)		

Technical Data	GT3-36KL1	GT3-36KL11	GT3-40KL1	GT3-40KL11
<b>PV Input Data</b>				
Max. DC Input Power [Wp]	150%			
Max. DC Input Voltage[V]	800			
Min PV input voltage[V]	180			
Start-up DC Input Voltage[V]	200			
Nominal DC Input Voltage[V]	370			
MPPT Operating Range[V]	180-700			
Max. DC Input Current[A]	4*40	6*40	4*40	6*40
Max. Short Circuit current[A]	4*52	6*52	4*52	6*52
No. of MPPTs	4	6	4	6
No. of Strings per MPP Trackers	4*2	6*2	4*2	6*2
<b>AC Output Data</b>				
Nominal Output Power [W]	36000	36000	40000	40000
Max. Apparent Power [VA]	39600	39600	44000	44000
Rated AC Grid Output Current[A]	94.5	94.5	105.0	105.0
Max. AC Output Current[A]	103.9	103.9	115.5	115.5
Rated AC Grid Voltage[V]	3L/ (N) /PE,220/127			
Rated Grid Frequency [Hz]	50/60			
Power Factor	> 0.99 Rated power (Adjustable 0.8 Leading - 0.8Lagging)			
Output THDi (@Nominal Output)	<3%			
<b>Efficiency</b>				
Max. Efficiency[%]	98.50%	98.50%	98.50%	98.50%
Euro Efficiency[%]	98.30%	98.30%	98.30%	98.30%
MPPT Efficiency[%]	>99			
<b>General Data</b>				
Dimensions[W*H*D] [mm]	960*725*361			
Weight [kg]	≤87			
Mounting Information	Wall Mounting			
Protection Degree	IP66			
Cooling	Smart forced air cooling			
Operating Temperature Range [°C]	-30 °C ... +60 °C (derating at 45°C)			
Relative Humidity	0-100%			
Max. Operating Altitude[m]	4000(≥3000)			
Typical Noise Emission[dB]	< 75			
Night Self Consumption [W]	< 4			
Display	LED+APP			
Communication	RS485 (Meter/GEN/DRM 0/CAN) ,Wi-Fi			
Topology	Transformerless			
<b>Certifications and Standards</b>				
Grid Regulation	IEC61727, IEC62116, EN50549			
Safety	IEC62109-1/-2			
EMC	EN61000-6-1/2/3/4			
Standard Warranty[years]	5 /10 (optional)			

Technical Data	GT3-50KL11	GT3-50KL1	GT3-60KL12	GT3-60KL11
<b>PV Input Data</b>				
Max. DC Input Power [Wp]	150%			
Max. DC Input Voltage[V]	800			
Min PV input voltage[V]	180			
Start-up DC Input Voltage[V]	200			
Nominal DC Input Voltage[V]	370			
MPPT Operating Range[V]	180-700			
Max. DC Input Current[A]	4*40	6*40	4*40	6*40
Max. Short Circuit current[A]	4*52	6*52	4*52	6*52
No. of MPPTs	4	6	4	6
No. of Strings per MPP Trackers	4*2	6*2	4*2	6*2
<b>AC Output Data</b>				
Nominal Output Power [W]	50000	50000	60000	60000
Max. Apparent Power [VA]	55000	55000	66000	66000
Rated AC Grid Output Current[A]	131.2	131.2	157.5	157.5
Max. AC Output Current[A]	144.3	144.3	173.2	173.2
Rated AC Grid Voltage[V]	3L/ (N) /PE,220/127			
Rated Grid Frequency [Hz]	50/60			
Power Factor	> 0.99 Rated power (Adjustable 0.8 Leading - 0.8Lagging)			
Output THDi (@Nominal Output)	<3%			
<b>Efficiency</b>				
Max. Efficiency[%]	98.50%	98.50%	98.50%	98.50%
Euro Efficiency[%]	98.30%	98.30%	98.30%	98.30%
MPPT Efficiency[%]	>99			
<b>General Data</b>				
Dimensions[W*H*D] [mm]	960*725*361			
Weight [kg]	≤87			
Mounting Information	Wall Mounting			
Protection Degree	IP66			
Cooling	Smart forced air cooling			
Operating Temperature Range [°C]	-30 °C ... +60 °C (derating at 45°C)			
Relative Humidity	0-100%			
Max. Operating Altitude[m]	4000(≥3000)			
Typical Noise Emission[dB]	< 75			
Night Self Consumption [W]	< 4			
Display	LED+APP			
Communication	RS485 (Meter/GEN/DRM 0/CAN) ,Wi-Fi			
Topology	Transformerless			
<b>Certifications and Standards</b>				
Grid Regulation	IEC61727, IEC62116, EN50549			
Safety	IEC62109-1/-2			
EMC	EN61000-6-1/2/3/4			
Standard Warranty[years]	5 /10 (optional)			

Technical Data	GT3-60KL1	GT3-75KL11	GT3-75KL1
<b>PV Input Data</b>			
Max. DC Input Power [Wp]	150%		
Max. DC Input Voltage[V]	800		
Min PV input voltage[V]	180		
Start-up DC Input Voltage[V]	200		
Nominal DC Input Voltage[V]	370		
MPPT Operating Range[V]	180-700		
Max. DC Input Current[A]	8*40	6*40	8*40
Max. Short Circuit current[A]	8*52	6*52	8*52
No. of MPPTs	8	6	8
No. of Strings per MPP Tackers	8*2	6*2	8*2
<b>AC Output Data</b>			
Nominal Output Power [W]	60000	75000	75000
Max. Apparent Power [VA]	66000	75000	75000
Rated AC Grid Output Current[A]	157.5	196.8	196.8
Max. AC Output Current[A]	173.2	196.8	196.8
Rated AC Grid Voltage[V]	3L/ (N) /PE,220/127		
Rated Grid Frequency [Hz]	50/60		
Power Factor	> 0.99 Rated power (Adjustable 0.8 Leading - 0.8Lagging)		
Output THDi (@Nominal Output)	<3%		
<b>Efficiency</b>			
Max. Efficiency[%]	98.50%	98.50%	98.50%
Euro Efficiency[%]	98.30%	98.30%	98.30%
MPPT Efficiency[%]	>99		
<b>General Data</b>			
Dimensions[W*H*D] [mm]	960*725*361		
Weight [kg]	≤87		
Mounting Information	Wall Mounting		
Protection Degree	IP66		
Cooling	Smart forced air cooling		
Operating Temperature Range [°C]	-30 °C ... +60 °C (derating at 45°C)		
Relative Humidity	0-100%		
Max. Operating Altitude[m]	4000(≥3000)		
Typical Noise Emission[dB]	< 75		
Night Self Consumption [W]	< 4		
Display	LED+APP		
Communication	RS485 (Meter/GEN/DRM 0/CAN) ,Wi-Fi		
Topology	Transformerless		
<b>Certifications and Standards</b>			
Grid Regulation	IEC61727, IEC62116, EN50549		
Safety	IEC62109-1/-2		
EMC	EN61000-6-1/2/3/4		
Standard Warranty[years]	5 /10 (optional)		

Technical Data	GT3-100KM11	GT3-100KM1	GT3-124KM11	GT3-124KM1
<b>PV Input Data</b>				
Max. DC Input Power [Wp]	150%			
Max. DC Input Voltage[V]	1100			
Min PV input voltage[V]	180			
Start-up DC Input Voltage[V]	200			
Nominal DC Input Voltage[V]	720			
MPPT Operating Range[V]	180-1000			
Max. DC Input Current[A]	8*40	10*40	8*40	10*40
Max. Short Circuit current[A]	8*52	10*52	8*52	10*52
No. of MPPTs	8	10	8	10
No. of Strings per MPP Tackers	8*2	10*2	8*2	10*2
<b>AC Output Data</b>				
Nominal Output Power [W]	100000	100000	124000	124000
Max. Apparent Power [VA]	110000	110000	124000	124000
Rated AC Grid Output Current[A]	120.3	120.3	149.2	149.2
Max. AC Output Current[A]	132.3	132.3	149.2	149.2
Rated AC Grid Voltage[V]	3L/ (N) /PE,277/480			
Rated Grid Frequency [Hz]	50/60			
Power Factor	> 0.99 Rated power (Adjustable 0.8 Leading - 0.8Lagging)			
Output THDi (@Nominal Output)	<3%			
<b>Efficiency</b>				
Max. Efficiency[%]	98.80%	98.80%	98.80%	98.80%
Euro Efficiency[%]	98.40%	98.40%	98.40%	98.40%
MPPT Efficiency[%]	>99			
<b>General Data</b>				
Dimensions[W*H*D] [mm]	960*725*361			
Weight [kg]	≤86			
Mounting Information	Wall Mounting			
Protection Degree	IP66			
Cooling	Smart forced air cooling			
Operating Temperature Range [°C]	-30 °C ... +60 °C (derating at 45°C)			
Relative Humidity	0-100%			
Max. Operating Altitude[m]	4000(≥3000)			
Typical Noise Emission[dB]	< 75			
Night Self Consumption [W]	< 4			
Display	LED+APP			
Communication	RS485 (Meter/GEN/DRM 0) ,Wi-Fi			
Topology	Transformerless			
<b>Certifications and Standards</b>				
Grid Regulation	IEC61727, IEC62116, EN50549			
Safety	IEC62109-1/-2			
EMC	EN61000-6-1/2/3/4			
Standard Warranty[years]	5 /10 (optional)			

Technical Data	GT3-125KM11	GT3-125KM1	GT3-150KM1
<b>PV Input Data</b>			
Max. DC Input Power [Wp]	150%		
Max. DC Input Voltage[V]	1100		
Min PV input voltage[V]	180		
Start-up DC Input Voltage[V]	200		
Nominal DC Input Voltage[V]	720		
MPPT Operating Range[V]	180-1000		
Max. DC Input Current[A]	8*40	10*40	10*40
Max. Short Circuit current[A]	8*52	10*52	10*52
No. of MPPTs	8	10	10
No. of Strings per MPP Trackers	8*2	10*2	10*2
<b>AC Output Data</b>			
Nominal Output Power [W]	125000	125000	150000
Max. Apparent Power [VA]	137500	137500	165000
Rated AC Grid Output Current[A]	150.4	150.4	180.4
Max. AC Output Current[A]	165.4	165.4	198.5
Rated AC Grid Voltage[V]	3L/ (N) /PE,277/480		
Rated Grid Frequency [Hz]	50/60		
Power Factor	> 0.99 Rated power (Adjustable 0.8 Leading - 0.8Lagging)		
Output THDi (@Nominal Output)	<3%		
<b>Efficiency</b>			
Max. Efficiency[%]	98.80%	98.80%	98.80%
Euro Efficiency[%]	98.40%	98.40%	98.40%
MPPT Efficiency[%]	>99		
<b>General Data</b>			
Dimensions[W*H*D] [mm]	960*725*361		
Weight [kg]	≤86		
Mounting Information	Wall Mounting		
Protection Degree	IP66		
Cooling	Smart forced air cooling		
Operating Temperature Range [°C]	-30 °C ... +60 °C (derating at 45°C)		
Relative Humidity	0-100%		
Max. Operating Altitude[m]	4000(≥3000)		
Typical Noise Emission[dB]	< 75		
Night Self Consumption [W]	< 4		
Display	LED+APP		
Communication	RS485 (Meter/GEN/DRM 0) ,Wi-Fi		
Topology	Transformerless		
<b>Certifications and Standards</b>			
Grid Regulation	IEC61727, IEC62116, EN50549		
Safety	IEC62109-1/-2		
EMC	EN61000-6-1/2/3/4		
Standard Warranty[years]	5 /10 (optional)		

## 11 Decommissioning

### 11.1 Disassemble the Inverter

- Remove DC input line and AC output line of inverter.
- Wait for at least 5 minutes to power.
- Remove all cable connections from the inverter.
- Remove inverter from finger support the bracket.
- Remove the bracket if necessary.
- Load the inverter into the original package if possible.

### 11.2 Packing

- Load the inverter into the original package if possible.
- If the original package can not be found, you can also use the following requirements of the carton packaging:
  - Bearing capacity of more than 30 kg.
  - Easy to carry.
  - Can completely seal the cover.

### 11.3 Storage and transportation

- Store the inverter in a dry, temperature -40°C~70°C environment.
- Pay attention to less than four machines on each stack board
- During storage and transportation.

### 11.4 Waste disposal

If it is necessary to scrap the inverter or other related parts, be sure to send the waste inverter and packaging materials to the designated location for recycling by the relevant department.

## 12 Disclaimer

This series inverters are transported, used and operated under limited condition, such as environmental, electrical etc.

Livoltek shall not be able to provide the service, technical support or compensation under conditions listed below, including but not limited to:

- . Inverter is damaged or broken by force majeure (such as earthquake, flooding, thunderstorm, lighting, fire hazard, volcanic eruption etc.).
- . Inverter's warranty is expired and doesn't buy extended warranty.
- . Can't provide the inverter's SN, warranty card or invoice.
- . Inverter is damaged by man-made cause.
- . Inverter is used or operated against any items in local policy.
- . Inverter's installation, configuration, commissioning doesn't follow the requirements mentioned in this manual.
- . Inverter is installed, refitted or operated in improper ways mentioned in this manual without authority from Livoltek.
- . Inverter is installed, operated under improper environment or electrical condition mentioned in this manual without authority from Livoltek.
- . Inverter is changed, updated or disassembled on hardware or software without authority from Livoltek.
- . Obtain the communication protocol from other illegal channels.
- . Build monitoring, control system without authority from Livoltek.
- . Livoltek will keep right to explain all the contents in this user manual.